

# DEVELOPMENT OF AN EMBEDDED SYSTEM TO MEASURE SOIL MOISTURE

By

APARNA M. PAWAR \*

J. D. DESHPANDE \*\*

SUHAS N. PATIL \*\*\*

\*-\*\*\* Department of Electronics, Tuljaram Chaturchand College of Arts, Science and Commerce, Baramati, Maharashtra, India.

Date Received: 29/11/2020

Date Revised: 01/12/2020

Date Accepted: 15/02/2021

## ABSTRACT

*In the field of embedded technology, advancements are taking place due to emerging technologies. Emphasizing the deployment of the on chip resources of ARM LPC 2378 microcontroller, an embedded system is designed to measure soil moisture. Recently, agriculturists are demanding high-tech instrumentation to monitor various parameters such as temperature, light intensity, humidity, gas concentration, concentration of fertilizers, pH, soil moisture, etc. Out of various soil parameters, the soil moisture is playing significant roles on the crop growth. Considering this demand, an embedded system is designed to measure soil moisture and the results are interpreted in this paper. The sensor, comprising two steel electrodes, is designed in the laboratory and implemented. The on chip ADC of LPC 2378 is deployed. In order to provide better isolation, signal conditioning stage is designed around the instrumentation amplifier AD620. The firmware is designed in embedded C using SCARM. For calibration of the system test bed is designed in the laboratory. The system is implemented for the measurement of soil moisture and the results obtained are discussed.*

*Keywords: Embedded System, Soil Parameters, Soil Moisture, ARMLPC2378, Ad620.*

## INTRODUCTION

The recent trend is to develop an embedded system for measurement and control of various physical parameters. Due to tremendous advancement in integrated chip design, a novel and promising microcontrollers are available. Using those microcontrollers, one can develop dedicated systems, which could be more reliable and accurate. The development of embedded systems, based on microcontrollers is rather a ubiquitous and innovative field (Patil & Ladgaonkar, 2013; Patil et al., 2017). Therefore, students and technologist are attracted towards this field. The concept of high-tech agriculture is evolving in modern agriculture, wherein instrumentations in agriculture play vital role for monitoring and controlling. Particularly, in case of greenhouse and polyhouse applications, the measurement and control of the parameters such as humidity, temperature, light intensity, soil moisture, etc. plays significant role on the yield of the crops (Pawar et al., 2013). Considering these facts, it is proposed to develop an embedded system for measurement of soil moisture for

farm irrigation.

Many people attempted to build a device based on the 8051 microcontroller in the beginning. The applications of the 8051, however, are limited due to limited on-chip resources. As a result, more people are focusing on high-performance microcontrollers. PIC, AVR, and ARM series microcontrollers all have promising characteristics. Microcontrollers provide less number of codes, high code density, single cycle instructions and pipelining, from which the speed of execution is significantly increased. Moreover, recently the ARM microcontroller ensures 32-bit framework of data acquisition and processing. Therefore, using on chip resources of ARM LPC 2378, an embedded system is designed for measurement of soil moisture of the farm and results are presented in this paper.

On literature survey it is found that, various techniques for determining water content of soil, from simple manure gravimetric sampling to more sophisticated remote sensing and Time Domain Reflectometry (TDR) measurements,

have been developed by different investigators (Roth et al., 1992; Topp et al., 2003). One common technique is to investigate the AC electrical properties such as, dielectric constant of soil. It is found that, the dielectric constant of the soil is sensitive to the moisture content of the same. Deploying appropriate calibration method, the dielectric constant measurement can be directly related to soil moisture (Topp et al., 1980). The measurement of soil moisture by using gravimetric method is the traditional method (Le Hégarat-Masclé et al., 2002). However, it is also found that, there are several different types of sensors commercially available in the market. In general, a manufacturer's calibration is commonly performed in a temperature controlled room, with distilled water and is easy to manage homogenous soil materials which are uniformly packed around the sensor (Chávez et al., 2011; Hignett & Evelt, 2008). This calibration procedure produces a very precise and accurate calibration for the conditions tested (Chávez et al., 2011). However, in field conditions, variations in clay content, temperature, and salinity may affect the manufacturer's calibration (Pawar et al., 2013). Therefore, to enhance the reliability of the present system under investigation, a testbed must be developed in the laboratory before implementing it in farm.

## 1. The Soil Moisture Sensor

Various soil moisture sensing sensors are available in the market, but for present system low cost and simple soil moisture sensor is designed in the laboratory and implemented to this dedicated application. On extensive study of literature, it is found that, the soil moisture sensors are of capacitive type and are used to measure the dielectric constant of the soil under test. The dielectric constant of the water is more than the dry soil. This is because of the fact that dry soil consists of very less number of charge carriers and hence the dielectric constant, which is mainly due to AC conductivity is very less. However, the water is conducting and hence the dielectric constant is high. Therefore, the dielectric constant of the soil is the function of concentration of water in the soil. Hence, by employing the principle of change in dielectric constant with the change in the water content of the soil, the soil sensor can be designed. However, to deploy the

capacitive sensor, more complex electronic circuit is essential to design. Therefore, it is always suggested to employ the principle of change in resistance due to water content. Thus, based on this principle the sensor is designed to measure soil moisture. It is our own design and depicted in Figure 1.

It consists of two electrodes of stainless steel and are separated by a distance of 2 cm. These are fixed at one end and other ends are kept free to insert into the soil sample under investigation. The high quality co-axial shielded cable is used to connect these two electrodes. The electrodes are resistive and it has to be excited with the energy source. Therefore, the sensor is excited with 1.5 volt. This excitation with low voltage reflects the conductivity due to charge carrier concentration, which is expected and not due to excessive drift velocity. Due to electrical conductivity, the potential is developed. This potential is highly sensitive to concentration of water in the soil. This potential is applied to further electric parts. The characteristics of this soil moisture sensor electrode are studied. This sensor is most successful and provides ubiquitous resistive sensor. The feature of the soil moisture sensor is described below.

- Extreme low cost with volume pricing.
- Conductivity based.
- Probe does not corrode over time.
- Small size and rugged design for long term use.
- Consumes less than 600  $\mu$ A for very low power operation.

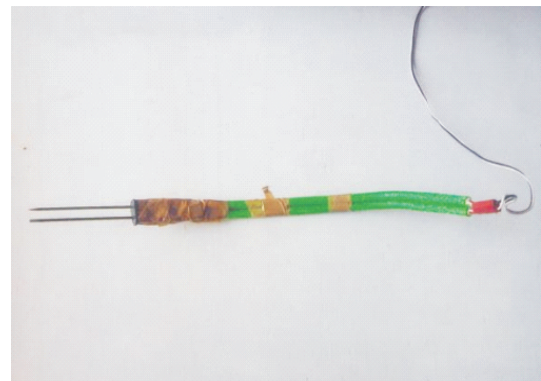

Figure 1. The Soil Moisture Sensor

- Precise measurement.
- Measures volumetric water content (VWC) or gravimetric water content (GWC).
- Output voltage is proportional to moisture level.
- Wide supply voltage range.

It produces water dependent voltage in millivolt range. The response is very fast and highly reliable. Series probes measure the dielectric constant of soil in order to find its volumetric water content (Chavez et al., 2011). Since the dielectric constant of water is much higher than that of air or soil minerals, the dielectric constant of the soil is a sensitive measure of water content.

## 2. The Embedded System Design

The hardware of the system called as circuit designed using ARM LPC 2378 microcontroller and depicted in the Figure 2. The designed system read very weak signal in millivolt range from the soil moisture sensor. In the design, it is necessary to isolate the sensor and rest of the circuits. Therefore, in order to provide better isolation, signal conditioning stage is wired using the very high input impedance instrumentation amplifier AD620. The gain of AD620 is adjusted to 1, so it is used here as buffer amplifier which helps to match the impedance between output stage of sensor and input stage of ARM microcontroller development board. This could help to maintain linearity

between observed output of the system and input voltage of soil moisture.

By proper signal conditioning circuitry, the signal soil moisture dependant emf in mV range is produced which is further digitized by deploying on chip ADC of ARM with 10 bit resolution. However, as per the need of sophisticated instrumentation, the parameters must be represented in respective engineering units. Which means the amount of water content of soil must be measured in percentage unit. Therefore, the soil moisture is displayed in % unit and the calibration of the system is essential and the system is further subjected to the process of calibration.

Actually, hardware and firmware are the two dimensions of an embedded system. The firmware is developed in embedded C using Keilu Vision for ARM, Integrated Development Environment (IDE). The developed firmware is depicted through the flow chart as shown in Figure 3. After successfully compiling and building the developed firmware, the IDE provides the .hex file, which is embedded into the flash memory of the target device LPC 2378.

## 3. Experimental Implementation

Emphasizing to the development, the embedded system for the measurement of the soil moisture using ARM LPC 2378 development board is designed and implemented. The place of implementation of the system is at the farm

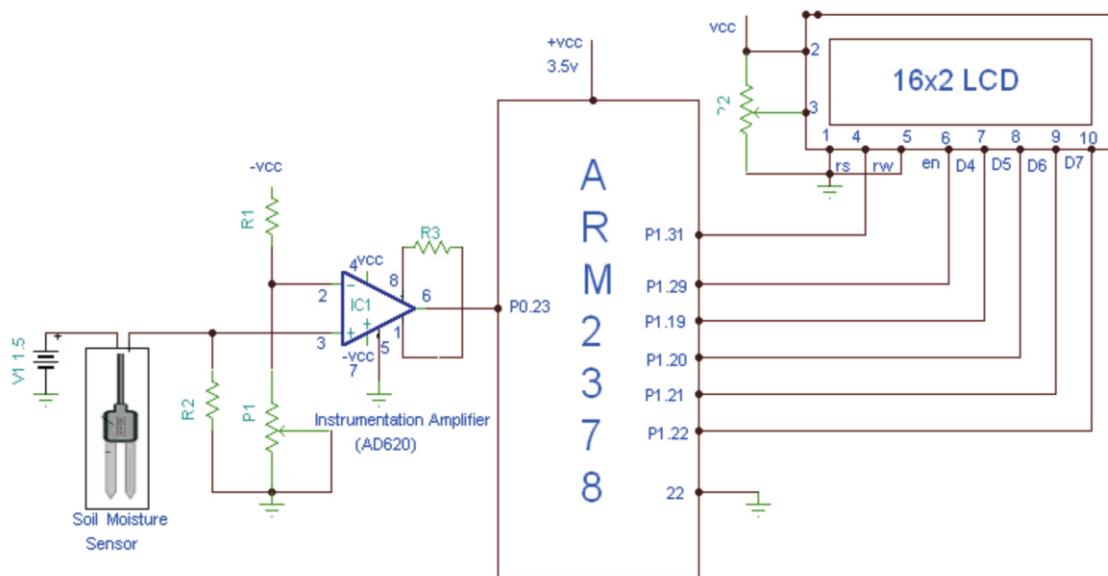

Figure 2. The Schematic of the System

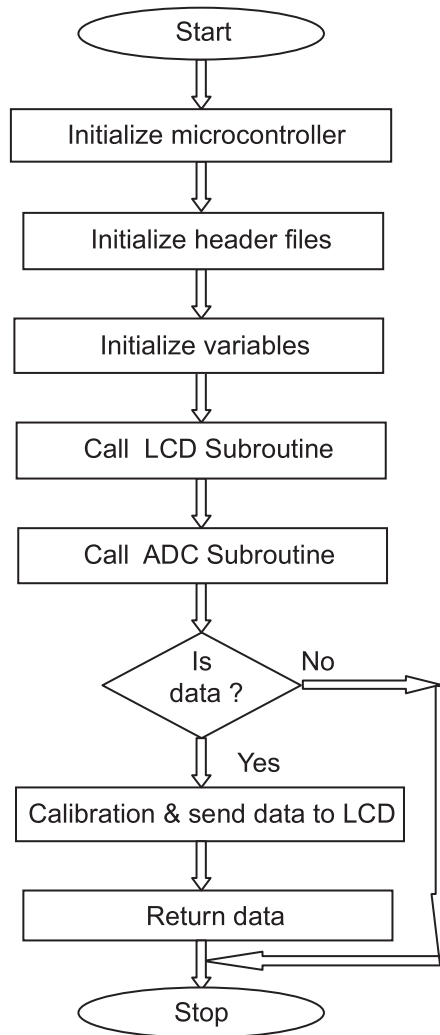

Figure 3. The Flow Chart of the Firmware

near to the crop. However, in order to perform experiment in the laboratory the testbed is designed. The soil sample under test is taken in the beaker of 500 ml capacity. The soil sample of 250 g is taken in the beaker. The density of the soil varies with nature of soil. The soil moisture sensor is inserted in these dry soil sample under test. The water is added, drop by drop, with the help of graduated burette and observation of relative moisture are recorded and presented in Table 1. The experimental set up is shown in Figure 4. The system is also implemented directly to measure the soil moisture at different places of the college garden as shown in Figure 5.

#### 4. Results and Discussion

An embedded system is developed about ARM LPC 2378



Figure 4. The Experimental Setup



Figure 5. A Picture of the Mounted Sensor While Irrigating a Farm

Sr. No	Water in ml	Observation Obtained from System (mV)
1	1	0
2	5	2.7
3	10	14.8
4	15	29.3
5	20	47.6
6	25	61.7
7	30	73.2
8	35	81.3
9	40	89.9
10	45	104.2
11	55	119.5
12	60	134.2
13	65	151.2
14	70	169.0
15	75	183.6
16	80	184.2
17	85	184.3
18	90	184.3

Table 1. The Relative Moisture Dependent emf

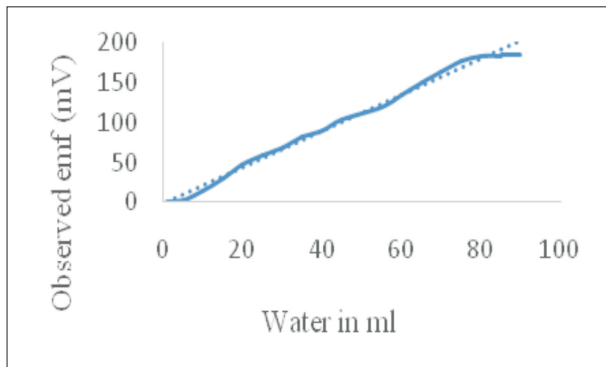

Figure 6. Percentage of Water Content in Soil Against Voltage

microcontroller to measure soil moisture. To measure the water content of the soil, a typical sensor is specifically designed and the hardware designed produces emf, which is proportional to the content of water in the soil. However, it is expected to have the observations of soil moisture either in relative units or in absolute units. Therefore, before implementation, the system is calibrated in the respective units.

For calibration of the system a sample of dry soil, of 250 g is taken in the beaker of 500 ml. The sensor is inserted in the dry soil and the emf produced by the system is measured in the beginning and it has been '0' volt. The water, drop by drop, is added by means of graduated burette and values noted as shown in Table 1. The readings of emf are taken against water in ml and plotted as shown in Figure 6. On inspection of figure, it is found that the emf increases almost linear with the water content. It is also observed that when water its not absorbed in soil, it flows on surface of soil and the emf remains constant. This condition is considered as 100% wet soil. The data available is best fitted to the straight line. The empirical relation obtained is,

$$\text{Soil moisture} = (\text{observed emf} + 1.46) / 2.26$$

This relation is incorporated in the firmware. Thus, the system is calibrated to the soil moisture in the gravimetric unit.

### Conclusion

Soil analysis is a valuable tool for the farm as it determines the inputs required for efficient and economic productivity. The reliability of the present system under investigation has been enhanced by a testbed developed in the laboratory and implemented in farm. The measurement of soil

moisture by gravitational method has been done. Thus the ARM LPC2378 embedded system is successfully developed to measure the soil moisture and it is working with great reliability and precision.

### References

- [1]. Chávez, J. L., Varble, J. L., & Andales, A. A. (2011). Performance evaluation of selected soil moisture sensors. In *Proceedings of the 2011 Central Plains Irrigation Conference* (pp. 29-38). Colorado State University Libraries.
- [2]. Hignett, C., & Evett, S. (2008). *Direct and surrogate measures of soil water content*. Vienna, Austria: International Atomic Energy Agency.
- [3]. Le Hégarat-Masclé, S., Zribi, M., Alem, F., Weisse, A., & Loumagne, C. (2002). Soil moisture estimation from ERS/SAR data: Toward an operational methodology. *IEEE Transactions on Geoscience and Remote Sensing*, 40(12), 2647-2658.
- [4]. Patil, S. N., & Ladgaonkar, B. P. (2013). Synthesis and Implementation of NiZnFe<sub>2</sub>O<sub>4</sub> ferrites to design embedded system for humidity measurement. *International Journal of Advanced Research in Electrical, Electronics and Instrumentation Engineering*, 2(8), 3813-3821.
- [5]. Patil, S. N., Pawar, A. M., & Ladgaonkar, B. P. (2017). Synthesis and deployment of nanoferrites to design embedded system for monitoring of ammonia gas. *International Journal of Engineering and Advanced Technology (IJEAT)*, 6, 27-31
- [6]. Pawar, A. M., Patil, S. N., Powar, A. S., & Ladgaonkar, B. P. (2013). Wireless sensor network to monitor spatio-temporal thermal comfort of polyhouse environment. *International Journal of Innovative Research in Science, Engineering and Technology*, 2(10), 4866-4875.
- [7]. Roth, C. H., Malicki, M. A., & Plagge, R. (1992). Empirical evaluation of the relationship between soil dielectric constant and volumetric water content as the basis for calibrating soil moisture measurements by TDR. *Journal of Soil Science*, 43(1), 1-13.
- [8]. Topp, G. C., Davis, J. L., & Annan, A. P. (1980). Electromagnetic determination of soil water content: Measurements in coaxial transmission lines. *Water*

*Resources Research*, 16(3), 574-582.

[9]. Topp, G. C., Davis, J. L., & Annan, A. P. (2003). The early

development of TDR for soil measurements. *Vadose Zone Journal*, 2(4), 492-499.

---

## ABOUT THE AUTHORS

*Dr. Aparna M. Pawar is presently working as Assistant Professor at Tuljaram Chaturch and College, Baramati, Maharashtra, India. She completed her Ph.D. degree from Solapur University, Solapur, Maharashtra, India. Her area of research is Embedded Technology, Wireless Sensor Network and Instrumentation Designing for Hi-Tech Agriculture. She was awarded with best paper presentation award at Research Festival, five times. She presented 33 research papers in National level conferences and published 16 papers in International Journal.*



*Dr. J. D. Deshpande is presently the Head, Department of Electronics at Tuljaram Chaturch and College, Baramati, Pune, Maharashtra, India. He completed his Ph.D from Pune University, Pune, Maharashtra, India. His area of research is Embedded Technology and Sensor Development.*



*Dr. Suhas N. Patil is presently working as Assistant Professor at Tuljaram Chaturch and College, Baramati, Maharashtra, India. He completed his Ph.D degree in Electronics. His area of research is the development of Smart Sensor Module, Embedded Technology, Wireless Sensor Network and Instrumentation Designing. He has been awarded with best paper presentation award at Research Festival, four times, organized by Solapur University, Solapur, Maharashtra, India. He presented 37 research papers in National level conferences and published 20 papers in International Journal.*

