



e-ISSN: 2278-8875

p-ISSN: 2320-3765

International Journal of Advanced Research

in Electrical, Electronics and Instrumentation Engineering

Volume 10, Issue 3, March 2021

ISSN INTERNATIONAL
STANDARD
SERIAL
NUMBER
INDIA

Impact Factor: 7.122

Principal
Tujaram Chaturchand College
Baramati

9940 572 462

6381 907 438

ijareeie@gmail.com

www.ijareeie.com



Design and Development of Multi Platform Multi Sensor Based Smart Baby Cradle Using IOT

Aniket Kothawale¹, Shital Gawade², Dr.Jagdish Deshpande³

Department of Electronics Science, T.C. College Baramati(M.S.), India^{1,2,3}

ABSTRACT: In the digital era of modern world ,new born baby become a challenge to most of the families. most of the parents send their babies to baby care house or their grand parents house.The duty of new born baby mostly on women. women play important role of hurdle& question marked on health, secureness of a baby.so for this those parents belief in modern technology we are proposing smart cradle system for baby .this paper present the implementation of smart baby cradle that swing mechanically once the baby cries & rotating toys as per the parents order. Proposed system will decrease the difficulty & release the stress of parents this system sense the wet condition & temperature condition.

KEYWORDS: Smart cradle, sound sensor, Microcontroller, Motion sensor, Wet sensor, Temperature sensor, DC Motor.

I. INTRODUCTION

The term IOT means internet of thing which is generally designed to save our time and make work easy. By using IOT we have designed a cradle system which make parents stress free and it is secure for baby
In this work we have developed a multisensor based smart cradle system using IOT. If baby has done pee and no one know for long time our system will send alert message to parents about wetness in cradle.
This system will give the relax time for parents & make them less stress. If baby is crying the cradle will swing automatically if baby has fever or cold the smart cradle send alert to parents.
The proposed system definitely help to parents so that they became less stress and they can good take care of their baby and stay healthy.

II. LITERATURE REVIEW

Dr.Andrew Racwiczfanchaoyuliu, et al[1] they proposed a system on design specification of smart baby cradle prototype system. In this they consider all the safety requirements. This system have limitation of baby curiousness.
RachanaPaslakar,et al [2] They proposed the cradle mechanism to record babies temperature ,to video record activities of baby and facial expression and send alert message. The drawback of this system is it uses AI to sense emotion because of this cost of system increases.
Tushar patekar,et al[3] They suggest all the motion that can be given by mother with voice and motion sensor control through mobile. The main limitation of the system that the sensor is located at the bottom of cradle so swing does not occur properly.
Aquib Nawaz, et al[4] they proposed a system that monitor the movement of baby and check wet condition. The limitation of system is that there is no swinging cradle automatically.
A.B.Tupkar, et al[5]They stated a system with automation it check body temperature ,bed wet and baby movement but this system have limitation of internet connection.



III. SYSTEM DEVELOPMENT

The Basic Block diagram of the system is shown in below in above figure major component are:- sound sensor, Microcontroller, Motion sensor, Wet sensor, Temperature sensor, DC Motor, Servo motor.

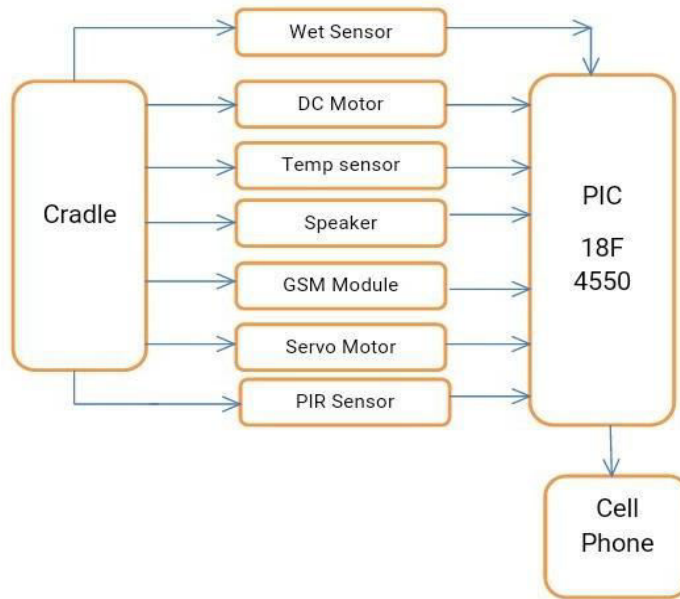

Working- When child is ready for sleep in cradle various sensor like noise sensor, PIR, wet sensor ,temperature sensor are used to monitor the child .firstly if the baby is in cradle the system is activated. When baby is crying the noise sensor gets input and system activate the music through Speaker and swing cradle is performed. Swing of cradle is performed by servo motor and toy start rotating due to DC motor.

When system detect wet condition due to pee the system send message to parent through GSM and make alarm through speaker. PIR sensor is used to detect the movement of child inside the cradle. When baby turn to left or right side the current status is send to parents mobile.

The temperature sensor is used to detect temperature around the cradle. If the temperature around the cradle is change baby feel discomfort at that time cradle start swing automatically.

Microcontroller

Microcontroller is compact IC designed for particular operation in embedded system.It include processor ,memory& input/output on single chip microcontroller are designed for embedded application.PIC 18F4550 is one of the most advanced microcontroller from microchip .This controller is generally used for modern application reason is that it have low cost, high quality.It is ideal for low power & connectivity application that benefit from the available serialport



GSM

The term GSM indicate global system for mobile communication. It make communication from one place to a different place. GSM establishes communication between computer &GSM & GPRS.





When any event occur the system will response the inform to person by making voice call & SMS.GSM continuously checking messaging activities forperson.

System Requirement- Hardware Requirement-

Cradle,Pic18f4550, GSM Module, Power supply ,Battery ,Wet sensor ,Toy, DC Motor, Servo Motor PIR Sensor, Temperature Sensor.

Software Requirement Windows XP and Above MPLAB

IV. CONCLUSION

This system reduce the stress of mother in working time the main advantages of this system is low cost and low operating cost. It improve the standard of kid care system as it use GSM technology it make user communicate for extended distance. It is more superior system to watch baby health care from any location.

REFERENCES

1. Dr. Andrew Rawicz, Fanchao Yu Liu,Xiango Lu, Kiru Sri, *Proposal for Smart Baby Cradle*, SimonFraser University, 24th Jan 2016
2. Rachna Palaskar, Shweta Pandey, AshwinTelang,AkshadaWagh, Ramesh R. Kagalkar,“An AutomaticMonitoring and Swing the Baby Cradle for Infant Care” Int. J. of Advanced Research in Computer and Commun. Eng., Dec.2015.
3. Tushar P. Patekar “Design and fabrication of automaticbaby cradle system” by Volume- 05 Issue 02 International Research Journal of Engineering and Technology (IRJET) 02 | Feb-2018.
4. Aquib Nawaz, “Development of an Intelligent Cradle forHome and Hospital Use”, National Inst. of Technology, 2015.
5. Prof. A.B. Tupkar , Prajwal. Chahare“Development of IoT Based Smart Baby Cradle”International Advanced Research Journal in Science, Engineering and Technology Vol. 7, Issue 1` January 2020
6. Prof. A.D. Anijkar et.al., “General Idea about Smart BabyCradle”, Int. J. of Innovative Science and Eng., Jan-Feb 2014.
7. Prof. A. R. Patil, “Smart Baby Cradle an IOT based Cradle Management System.”, 2018 International Conference on Smart City and Emerging Technology (ICSCET).
8. Sharmadha Senthil Nathan, Shivani Kanmani, Shruthi Kumar, Madheswari Kanmani *Survey on Digital Age-Smarter Cradle System for Enhanced Parenting*. 2018

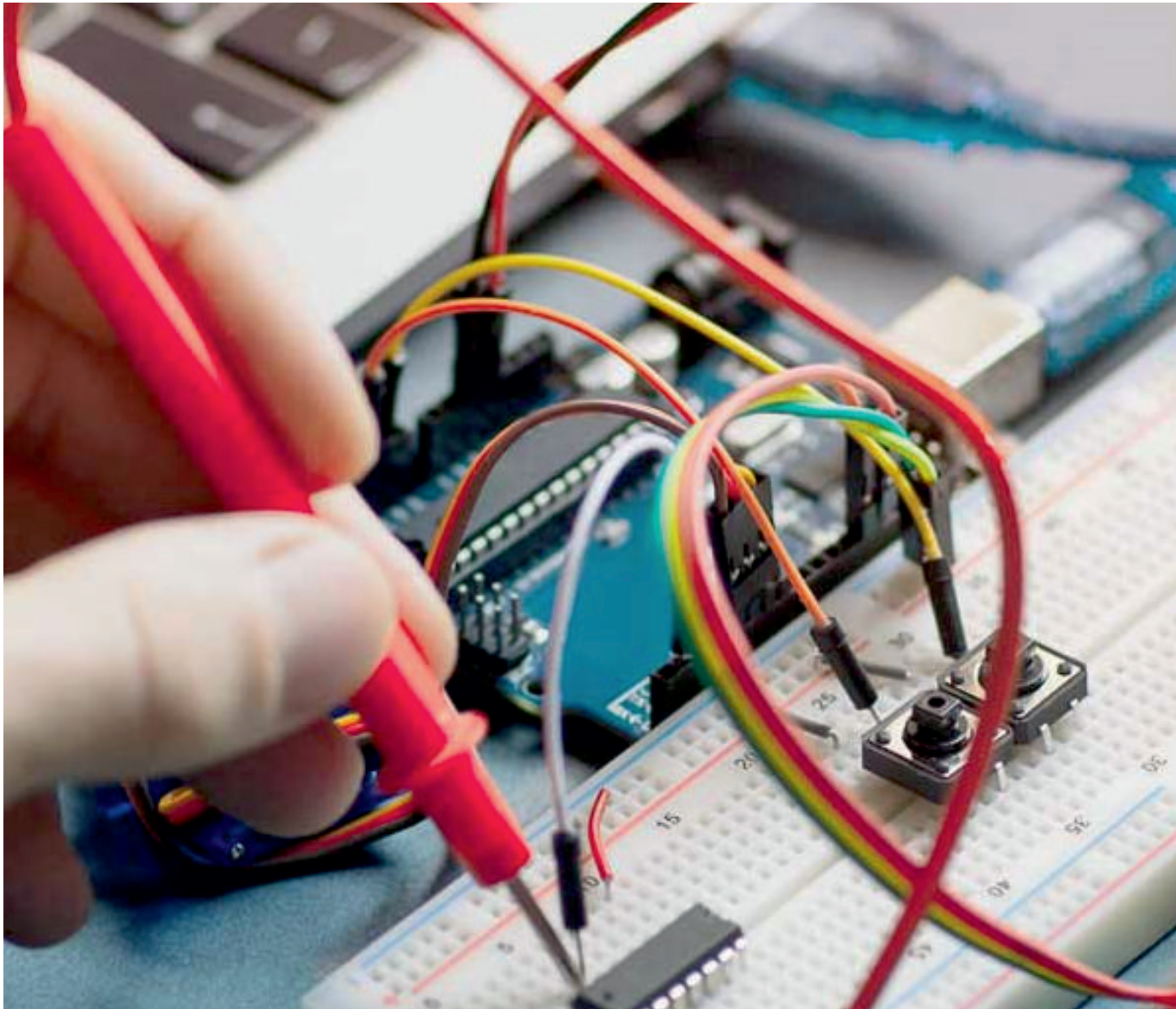

INNO  **SPACE**
SJIF Scientific Journal Impact Factor

Impact Factor:
7.122

ISSN INTERNATIONAL
STANDARD
SERIAL
NUMBER
INDIA



International Journal of Advanced Research

in Electrical, Electronics and Instrumentation Engineering

Principal
Tujaram Chaturchand College
Baramati



 **9940 572 462**  **6381 907 438**  **ijareeie@gmail.com**



www.ijareeie.com

Scan to save the contact details